



## SPECIFICATION

宏致電子股份有限公司

桃園縣中壢市東園路13號

No.13, Dongyuan Rd., Jhongli City,

Taoyuan County 320, Taiwan (R.O.C.)

TEL: +886-3-463-2808

FAX: +886-3-463-1800

SPEC. NO.: PS-50208-XXXXX-XXX

REVISION: M

PRODUCT NAME: 0.8 mm PITCH IDC CONNECTOR

PRODUCT NO: 50208 ,50207,50375,50450,50209,51218 SERIES

PREPARED:  <b>LI JIN</b>  DATE: <b>2016/07/27</b>	CHECKED:  <b>BRAVE</b>  DATE: <b>2016/07/27</b>	APPROVED:  <b>FRANK</b>  DATE: <b>2016/07/27</b>
--	--	---



Aces P/N:

**50208,50207,50375,50450,50209,51218SERIES**

**TITLE: 0.8 MM PITCH IDC CONNECTOR**

RELEASE DATE: 2015/12/7

REVISION: K

ECN No: **ECN-1607431**

PAGE: **2** OF **15**

1	REVISION HISTORY .....	3
2	SCOPE.....	4
3	APPLICABLE DOCUMENTS .....	4
4	REQUIREMENTS .....	4
5	PERFORMANCE .....	5
6	INSERTION / EXTRACTION FORCE .....	7
7	INFRARED REFLOW CONDITION.....	8
8	APPLICABLE SPECIFICATIONS.....	8
9	CONTACT V.S WIRE RETENTION FORCE TABLE.....	9
10	RODUCT QUALIFICATION AND TEST SEQUENCE.....	10
11	TERMINATION DEPTH.....	11
12	TERMINATION APPEARANCE .....	11
13	MATING/UNMATING METHOD CONNECTOR.....	13



Aces P/N:

**50208,50207,50375,50450,50209,51218**SERIES

TITLE: **0.8 MM PITCH IDC CONNECTOR**

RELEASE DATE: 2015/12/7

REVISION: K

ECN No: **ECN-1607431**

PAGE: **3** OF **15**

## 1 Revision History

Rev.	ECN #	Revision Description	Prepared	Date
O	ECN-0812210	NEW RELEASE	JASON	2008.11.24
A	ECN-0904077	UPDATE P/N	JASON	2009.04.10
B	ECN-0909093	CHANGE CONTACT V,S WIRE RETENTION FORCE	JASON	2009.09.12
C	ECN-0912051	UPDATE AWG WIRES	JASON	2009.12.07
D	ECN-1103068	RELEASE	GAVIN	2011.03.09
E	ECN-1103035	FOR 50450 RELEASE	BRAVE	2011.04.06
F	ECN-1111447	AMEND SPEC	GAVIN	2011.11.28
G	ECN-1205290	AMEND SPEC	CANDY	2012/05/21
H	ECN-1307462	ADD 50209 SERIES	DAVID	2013/07/30
J	ECN-1401156	ADD WORKING VOLTAGE	XUFEI	2014/01/09
K	ECN-1512083	Update All Group	JUGG	2015/12/7
L	ECN-1607243	ADD WIRE SPEC	LI JIN	2016/07/18
M	<b>ECN-1607431</b>	<b>ADD 51218 SERIES</b>	LI JIN	2016/07/27



Aces P/N:

**50208,50207,50375,50450,50209,51218SERIES**

TITLE: **0.8 MM PITCH IDC CONNECTOR**

RELEASE DATE: 2015/12/7

REVISION: K

ECN No: **ECN-1607431**

PAGE: **4** OF **15**

## 2 SCOPE

This specification covers performance, tests and quality requirements for **0.8 mm pitch IDC connector**.

Aces P/N : **50208 Series ,50207Series, 50375Series,50450Series, 50209Series, 51218 Series**

## 3 APPLICABLE DOCUMENTS

EIA-364: ELECTRONICS INDUSTRIES ASSOCIATION

## 4 REQUIREMENTS

### 4.1 Design and Construction

- 4.1.1 Product shall be of design, construction and physical dimensions specified on applicable product drawing.
- 4.1.2 All materials conform to R.o.H.S. and the standard depends on TQ-WI-140101.

### 4.2 Materials and Finish

Wire Connector

- 4.2.1 Terminal: High performance copper alloy.
  - Finish: (a) Contact Area: [Refer to the drawing](#).
  - (b) Under plate: [Refer to the drawing](#)
- 4.2.2 Housing: Thermoplastic or Thermoplastic High Temp., UL94V-0

Header Connector:

- 4.2.3 Contact: High performance copper alloy.
  - Finish: (a) Contact Area: [Refer to the drawing](#).
  - (b) Under plate: [Refer to the drawing](#).
- 4.2.4 Housing: Thermoplastic or Thermoplastic High Temp., UL94V-0
- 4.2.5 Fitting Nail: [Refer to the drawing](#).
  - Finish: [Refer to the drawing](#).

### 4.3 Ratings

- 4.3.1 [Working voltage less than 36 volts \(per pin\)](#)
- 4.3.2 Voltage: [50 Volts DC](#)
- 4.3.3 Current: [DC 0.7 Amperes AWG# 32](#)
- 4.3.4 Operating Temperature : [-25°C to +85°C](#)



Aces P/N:

**50208,50207,50375,50450,50209,51218SERIES**TITLE: **0.8 MM PITCH IDC CONNECTOR**

RELEASE DATE: 2015/12/7

REVISION: K

ECN No: **ECN-1607431**PAGE: **5** OF **15**

## 5 Performance

### 5.1. Test Requirements and Procedures Summary

Item	Requirement	Standard
Examination of Product	Product shall meet requirements of applicable product drawing and specification.	Visual, dimensional and functional per applicable quality inspection plan.
<b>ELECTRICAL</b>		
Low Level Contact Resistance	Initial: 30 m $\Omega$ max. After: 40 m $\Omega$ max.	Mate connectors and measure by dry circuit, 20m V max. 10m A (EIA-364-23)
Insulation Resistance	100 M $\Omega$ Min.	Unmated connectors, apply 500 V DC between adjacent terminals. (EIA-364-21)
Dielectric Withstanding Voltage	No Breakdown.	Mate connectors and apply 500 V AC/rms for 1 minute between adjacent terminal or ground (EIA-364-20)
Temperature rise	30°C Max. Change allowed	Mate connector: measure the temperature rise at rated current after: 0.7 A/Power contact. The temperature rise above ambient shall not exceed 30°C The ambient condition is still air at 25°C (EIA-364-70 METHOD 2)
<b>MECHANICAL</b>		
Item	Requirement	Standard
Durability	30 cycles.	The sample should be mounted in the tester and fully mated and unmated the number of cycles specified at the rate of 25.4 $\pm$ 3mm/min. (EIA-364-09)
Insertion /Extraction Forces (Mating/ Un-mating Force)	See item 6	Measure the force necessary to mate connector assemblies at a maximum rate of 25.4mm per minute. (EIA-364-13)
Wire pull out force	See item 9.	Fix the crimped terminal ,apply axial pull out force on the wire at speed rate of 25.4mm per minute.



Aces P/N:

**50208,50207,50375,50450,50209,51218SERIES**

**TITLE: 0.8 MM PITCH IDC CONNECTOR**

RELEASE DATE: 2015/12/7

REVISION: K

ECN No: **ECN-1607431**

PAGE: **6** OF **15**

Terminal/Housing Retention force	3N Min.	Apply axial pull out force at the speed rate of 25.4mm per minute on the terminal assembly in the housing
Vibration	1 $\mu$ s Max.	Amplitude : 1.5 mm P-P Sweep time : 10-55-10 Hz in 1 minute Duration : 2 hrs in each X.Y.Z. axis (EIA-364-28)
Shock	1 $\mu$ s Max.	Mate connectors and subject to the following shock conditions. 3 shocks shall be applied along 3 mutually perpendicular axes, passing DC 1mA current during the test. (Total of 18 shocks) Test Pulse : Half Sine Peak Value : 490m/s <sup>2</sup> [ 50G ] (EIA-364-27)

**ENVIRONMENTAL**

Thermal Shock	See Product Qualification and Test Sequence Group 4	Mate module and subject to follow condition for 5 cycles. 1 cycles: -55 +0/-3 °C, 30 minutes +85 +3/-0 °C, 30 minutes (EIA-364-32, test condition I)
Humidity	See Product Qualification and Test Sequence Group 4	Mated Connector 40°C, 90~95% RH, 96 hours. (EIA-364-31, Condition A, Method II)
Temperature Life	See Product Qualification and Test Sequence Group 5	Subject mated connectors to temperature life at 85°C for 96 hours. (EIA-364-17, Test condition A)
Salt Spray (Only For Gold Plating)	See Product Qualification and Test Sequence Group 6	Subject mated/unmated connectors to 5% salt-solution concentration, 35°C (I) Gold flash for 8 hours (II) Gold plating 5 $\mu$ " for 96 hours. (EIA-364-26)
Resistance to Soldering heat	Appearance: no damage contact resistance: 40 m $\Omega$ max	Temperature 260°C Max, 10 Sec Max. IR reflows 2 times
Solder-Ability	75% of immersed area must show no voids, pin holes	Temperature at 245 $\pm$ 5°C, for 4-5 sec. (EIA-364-52)
Hand Soldering Temperature Resistance	Appearance : No damage	T $\geq$ 350°C, 3 sec at least



Aces P/N:

**50208,50207,50375,50450,50209,51218**SERIES

TITLE: **0.8 MM PITCH IDC CONNECTOR**

RELEASE DATE: 2015/12/7

REVISION: K

ECN No: **ECN-1607431**

PAGE: **7** OF **15**

## 6 Insertion / Extraction Force

NO.OF.CKT	Initial		After 30 <sup>th</sup> Cycle
	Insertion Force (Max.)	Withdrawal Force (Min.)	Withdrawal Force (Min)
2	1.5KG	0.20KG	0.15KG
3			
4			
5	2.0KG	0.35KG	0.25KG
6			
7			
8			
9			
10			
11	3.0 KG	0.45KG	0.35KG
12			
13			
14			
15			
16			
17			
18			

**TITLE: 0.8 MM PITCH IDC CONNECTOR**

RELEASE DATE: 2015/12/7

REVISION: K

ECN No: **ECN-1607431**

PAGE: **8** OF **15**

## 7 INFRARED REFLOW CONDITION

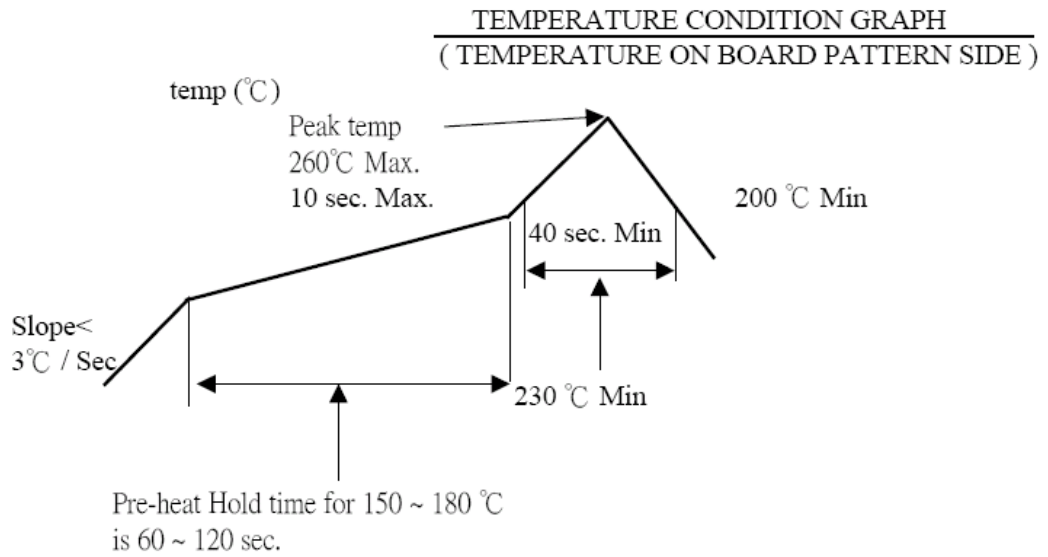

Lead-free Process

## 8 Applicable Specifications

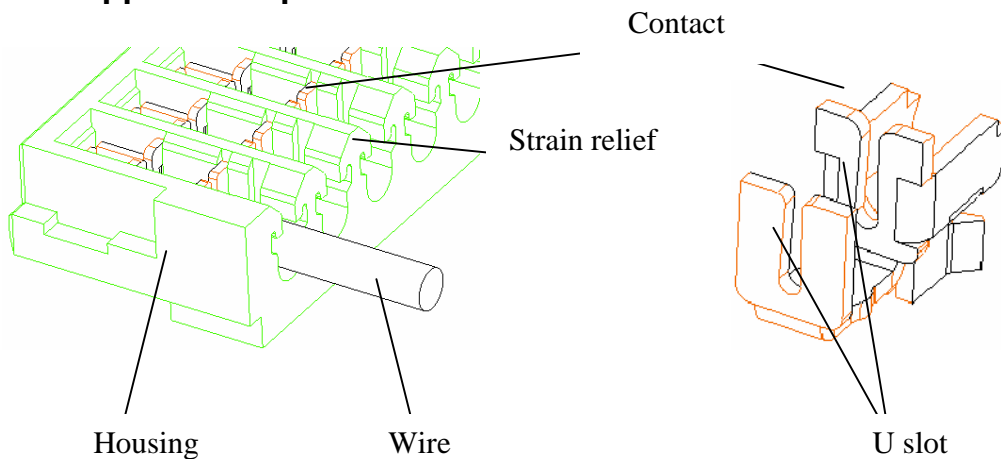



TITLE: **0.8 MM PITCH IDC CONNECTOR**

RELEASE DATE: 2015/12/7

REVISION: K

ECN No: **ECN-1607431**

PAGE: **9** OF **15**

**9 Contact V.S Wire Retention Force Table**

Insulation OD	Wire	Part No.	Material of insulation	Parallel	Perpendicular
Φ0.38±0.02	AWG #32 <b>7C</b> <b>(UL1867/UL10064)</b>	50375-xxxxx-001 50375-xxxxx-002 50375-xxxxx-A01 50375-xxxxx-004 <b>50375-xxxxx-005</b>	Halogen-free	6N min.	0.8N min.
	AWG #32	50375-xxxxx-003 50375-xxxxx-F01	Halogen-free	5N min.	1.5N min.

Note:

If need retention force more that must use the UV glue.

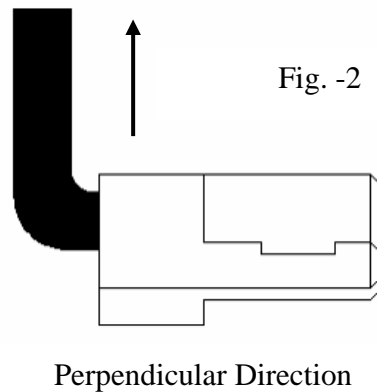
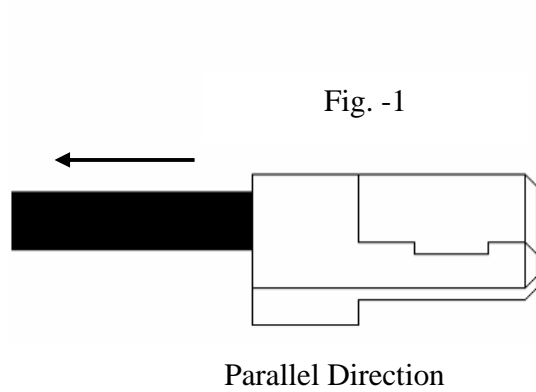



Aces P/N:

**50208,50207,50375,50450,50209,51218SERIES**

**TITLE: 0.8 MM PITCH IDC CONNECTOR**

RELEASE DATE: 2015/12/7

REVISION: K

ECN No: **ECN-1607431**

PAGE: **10** OF **15**

**10 PRODUCT QUALIFICATION AND TEST SEQUENCE**

Test or Examination	Test Group									
	1	2	3	4	5	6	7	8	9	10
	Test Sequence									
Examination of Product				1、7	1、6	1、4			1、3	1、3
Low Level Contact Resistance		1、5	1、4	2、10	2、9	2、5			4	
Insulation Resistance				3、9	3、8					
Dielectric Withstanding Voltage				4、8	4、7					
Temperature Rise	1									
Mating / Unmating Force		2、4								
Durability		3								
Vibration			2							
Shock (Mechanical)			3							
Thermal Shock				5						
Humidity				6						
Temperature Life					5					
Salt Spray(Only For Gold Plating)						3				
Wire Pull Out Force							1			
Terminal / Housing Retention Force (Cable Side)								1		
Resistance to Soldering Heat									2	
Hand Soldering Temperature Resistance										2
<b>Sample Size</b>	<b>2</b>	<b>4</b>	<b>4</b>	<b>4</b>	<b>4</b>	<b>4</b>	<b>4</b>	<b>4</b>	<b>4</b>	<b>4</b>

TITLE: **0.8 MM PITCH IDC CONNECTOR**

RELEASE DATE: 2015/12/7

REVISION: K

ECN No: **ECN-1607431**

PAGE: **11** OF **15**

## 11 TERMINATION DEPTH

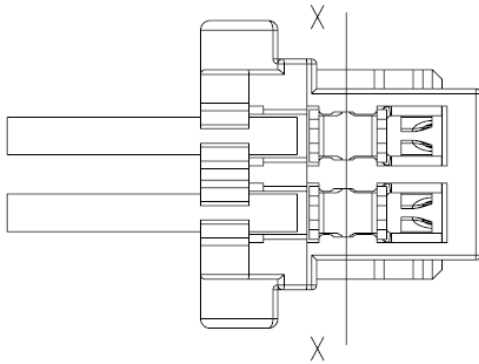

**Fig.-1**

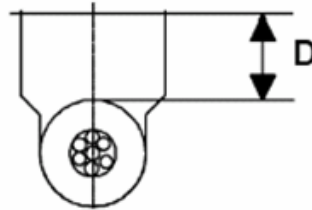

**Fig.-2**

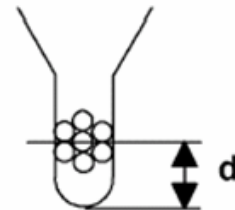

**Fig.-3**

Measure termination depth dimension “D” in Fig.-2 at X-X part in Fig.-1 where is in the middle part of two U slots and a flattened part pressed by termination punch, and check it satisfies specified value in table

Exact termination depth is measure “d” between bottom of slot and position of center core wire of wire conductors as shown in Fig.-3; Aces specifies termination depth dimension “D” force to facilitate a time-consuming work of measuring “d” as a daily control.

Accordingly, dimension “D” becomes not reference value but control value for the use of the wire to be checked is Aces expect specified wires.

Wire Size	Insulation OD	Termination Depth D	d
<b>AWG#32</b>	$\Phi 0.38 \pm 0.02 \text{mm}$	$D = 0.40 \pm 0.03 \text{mm}$	$d = 0.19 \pm 0.03 \text{mm}$

## 12 TERMINATION APPEARANCE

Inspect the following points after termination.

12.1 Punching flaws on housing caused by termination punch; Housing must be free from flaws. When connector set position deviation, scratches and deformation caused by termination punch may appear at the diagonally shaded areas in Fig.-4.

12.2 Flaws and deformation at beams of contact. Beams must be free from flaws and dimension. When connector set position deviation to wire axis direction, scratches and deformation caused by termination punch may appear at beams of contact as shown in Fig.-5.

In this case, not only contact but also termination die may be damaged.

**TITLE: 0.8 MM PITCH IDC CONNECTOR**

RELEASE DATE: 2015/12/7

REVISION: K

ECN No: **ECN-1607431**

PAGE: **12** OF **15**

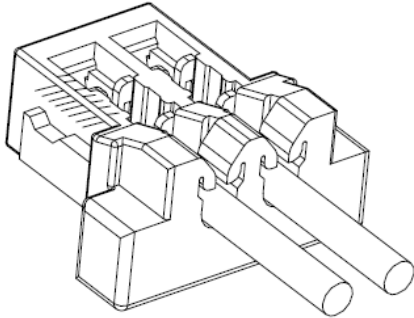

Fig.-4

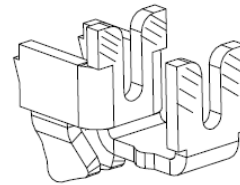
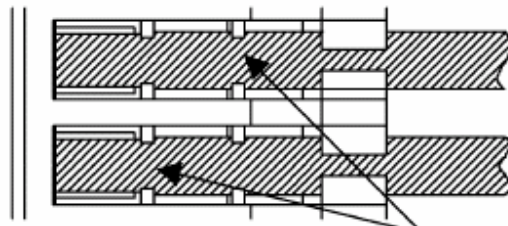

Fig.-5

12.3 Exposure of wire conductors around beams of contact; Wire conductors must not be exposed. When connector set position deviates to wire axis direction, wire conductors may expose in front or back of beams of contact as shown in Fig.-6.



Wire conductors must not be exposed.

Fig.-6

12.4 Gap between housing wall and wire tip (Wire protruding length) Gap "G" between housing walls and wires tip in Fig.-7 should be 0.2 mm max.

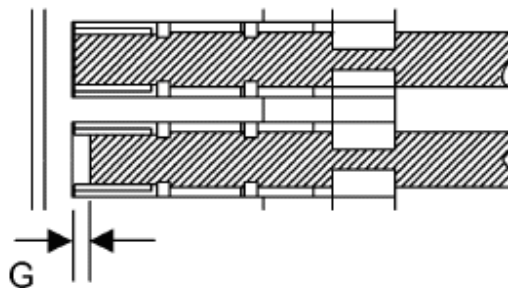

Fig.-7

TITLE: **0.8 MM PITCH IDC CONNECTOR**

RELEASE DATE: 2015/12/7

REVISION: K

ECN No: **ECN-1607431**

PAGE: **13** OF **15**

12.5 Overrun of wire (Wire must not overrun) when wire tension is not adequate, overrun of wire may appear as shown in Fig.-8.

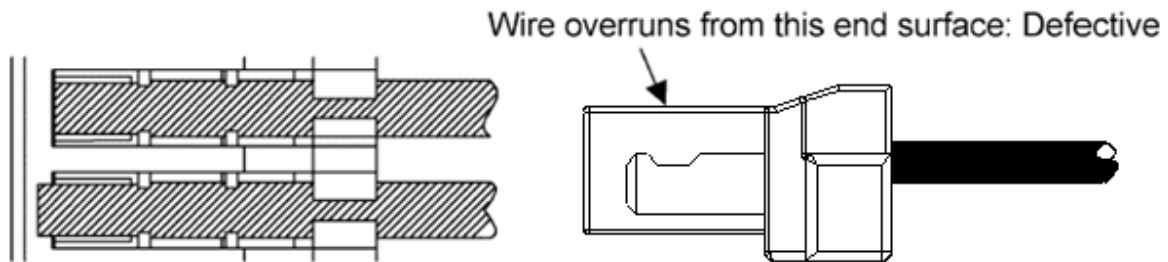

Fig.-8

12.6 Deviation of insulation displacement center (Deviation of insulation displacement center must not happen. When connector set position or wire deviates to pitch direction, termination punch, wire and U slots do not align so that insulation displacement center deviate as shown in Fig.-9 and Fig.-10

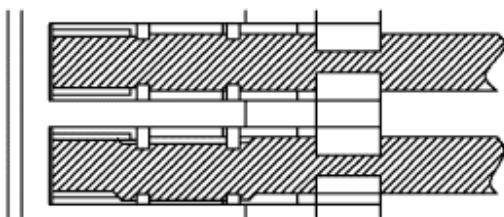

Fig.-9

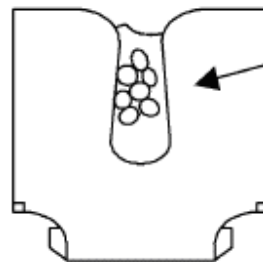

Fig.-10

### 13 MATING/UNMATING METHOD CONNECTOR

#### 13.1 Mating method of connector

Mated receptacle with header straight on same axis. When the position of mating part of header and receptacle is aligned, align one side of mating part of header with the end of receptacle within 20 degrees to mating axis as shown in Fig.-11.

Do not mate receptacle at the angle of 20 degrees or more, because such handling may cause breakage of connector, etc.

When position of receptacle and header is aligned, hold wires in a bundle in order to prevent applying external force to receptacle. Then, mate receptacle with header up to the back straight against mating axis.

Besides, after mating operation, check that there is no clearance between header and receptacle as shown in Fig.-12, because such clearance may lead discontinuity of connector.

**TITLE: 0.8 MM PITCH IDC CONNECTOR**

RELEASE DATE: 2015/12/7

REVISION: K

ECN No: **ECN-1607431**

PAGE: **14** OF **15**

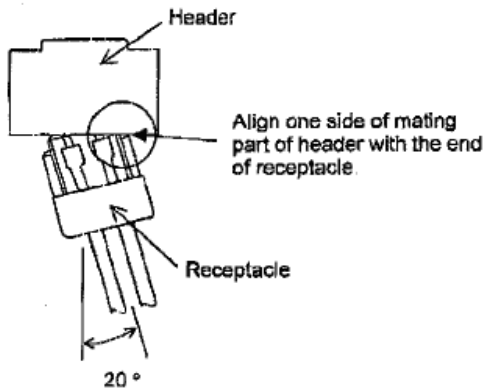

Fig.-11

Align the position (Side entry type)

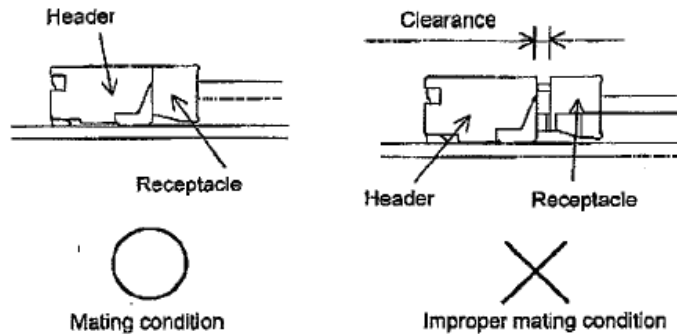

Fig.-12

Mating condition (Side entry type)

**13.2 Unmating method of connector**

Hold wires in a bundle and unmate receptacle from header on the same axis. At this time, conduct operation within 20 degrees to mating axis.

Do not unmate receptacle forcibly with prying more than 20 degrees, because such handling may cause breakage of connector, etc.

If receptacle is unmated with holding wire of only one end, such handling is the same as prying connector.

Beside, there is a possibility that wire may come off housing when they are unmated without holding in a bundle.

Even when all wires cannot be held in routing of wires, wire more than the number shown in the Table-1 should be held and unmated.

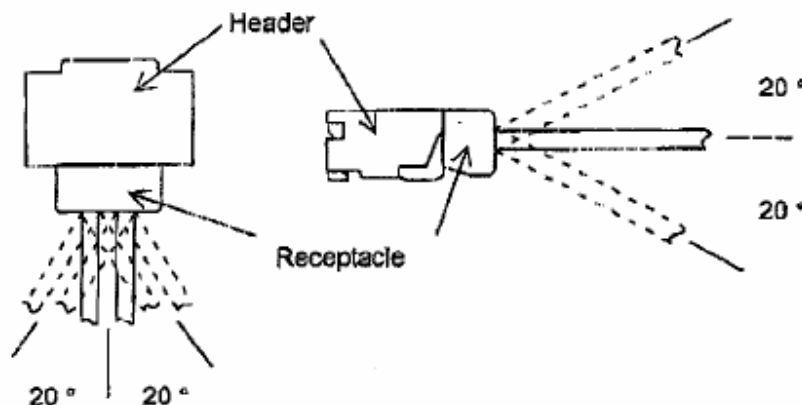

Fig.-13



Aces P/N:

**50208,50207,50375,50450,50209,51218SERIES**

**TITLE: 0.8 MM PITCH IDC CONNECTOR**

RELEASE DATE: 2015/12/7

REVISION: K

ECN No: **ECN-1607431**

PAGE: **15** OF **15**

CKTS	Wires
2	hold 2 wires without fail
3~5	hold more than 3 wires
6~10	hold more than 4 wires
11~15	hold more than 5wires
16~20	hold more than 6 wires

Table -1

### 13.3 Routing of wire

In routing wire, careful operation is required so that tension more than 1N may not be applied per connector and one wire (one circuit).